

Double-Break Beavertail



Add the Double-Break Beavertail option to your deck over model and you'll have one of the easiest loading/unloading trailers in the business. Option comes standard with 6' ramps and the 7'-6" beavertail goes from 12 degrees down to 6 degrees! The Double-Break Beavertail minimizes "high pointing" with a smooth transition from beavertail to flat deck. Ideal for excavators, trenching machines and other tracked machinery. Angle iron beavertail offers superior traction.



Angle-iron beavertail with 12° to 6° transition to deck.



6-foot angle-iron ramps.



Standard two-way spring assist ramps.

Quick Specs:

- 12° to 6° transition to deck
- 7'-6" length
- 6-ft. ramps
- Two-way spring-assist ramps
- Angle-iron cross slats

Available on:

- T-20
- T-24
- T-30
- T-40
- T-50
- T-50RG
- T-70RG

Photos may show optional equipment.

AMERICA'S BEST BUILT TRAILERS FOR PROFESSIONAL HAULERS



800-462-4517
TOWMASTER.COM



MORE MODELS • MORE OPTIONS • MORE CHOICES
DROP-DECK • TILT BED • DECK-OVER • GOOSENECK • LOWBOY • HYDRAULIC TAIL

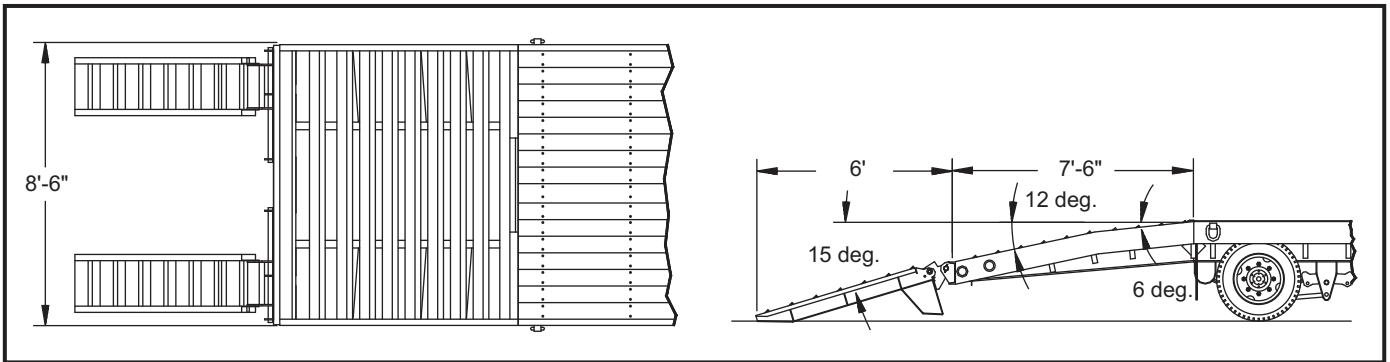

- AVAILABLE ON:**
- T-20
 - T-40
 - T-50RG
 - T-24
 - T-50
 - T-70RG
 - T-30

STANDARD EQUIPMENT

- Angle-iron cross slats
- 6 ft. angle-iron ramps
- Two-way spring assist

OPTIONAL EQUIPMENT

- Wood-covered

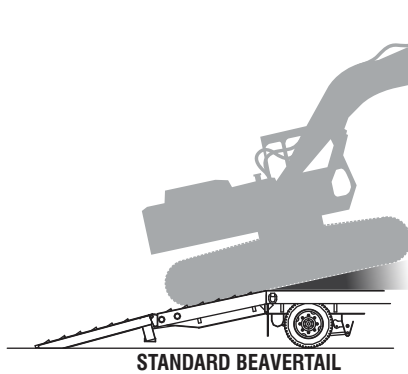

STANDARD BEAVERTAIL

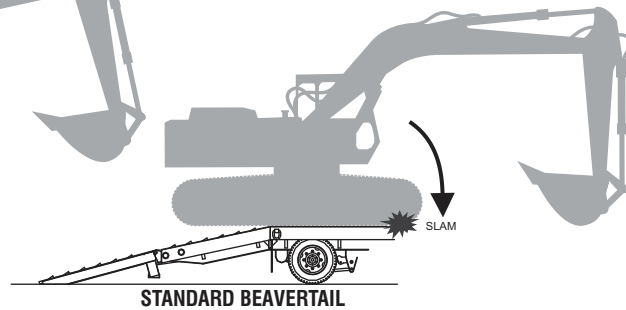

STANDARD BEAVERTAIL

On a standard beavertail, tracked equipment tends to “high-point” before the front of it “slams” onto the trailer deck, making loading and unloading a bit nerveing.

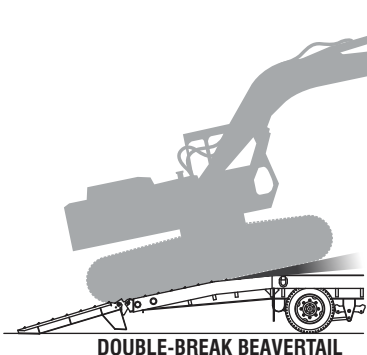

DOUBLE-BREAK BEAVERTAIL

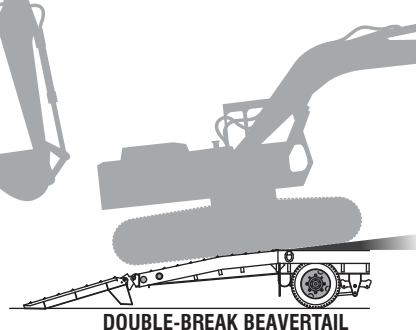

DOUBLE-BREAK BEAVERTAIL

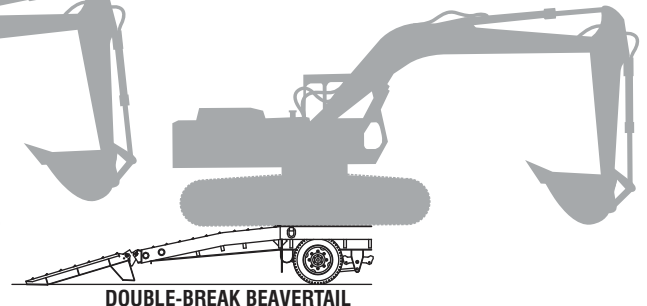

DOUBLE-BREAK BEAVERTAIL

With our double-break beavertail, tracked equipment eases onto the deck better, making loading and unloading easier on the operator and equipment.



*Payload capacity is calculated by taking the GVWR and subtracting the trailer weight. Listed GVWR, weights, and dimensions are for reference only. Manufacturer reserves the right to change models and specifications as they see fit. See our web site or your local authorized dealer for more information.