



Towmaster's® deck-over tilt trailers offer convenience and durability. No ramps to hassle with, simply tilt the deck and drive on or off. It features our patented automatic kick-out ramp that doubles as under-ride protection, a single-lever twin-latch system, stationary forward deck, Hutchens® suspension, and a deck cushion cylinder to ease the deck up and down.



Patented automatic kick-out ramp doubles as under-ride protection.



Cushion cylinder controls the deck tilt when loading or unloading equipment. Optional Hutchens® 9700 suspension shown.



4-foot stationary deck is standard and allows room for longer equipment and the added length makes towing easier.

Quick Specs:

- 32.5" deck height (loaded)
- 8'-6" deck width
- 24' tilt deck, 4' stationary
- Air brakes
- D-ring tie-downs
- Hutchens® suspension
- Kick-out ramp/under-ride protection
- Single-lever twin-latch locking system
- LED lights



Photos may show optional equipment.

AMERICA'S BEST BUILT TRAILERS FOR PROFESSIONAL HAULERS



800-462-4517
TOWMASTER.COM



GALVANIZING AVAILABLE



MORE MODELS • MORE OPTIONS • MORE CHOICES
DROP-DECK • TILT BED • DECK-OVER • GOOSENECK • LOWBOY • HYDRAULIC TAIL

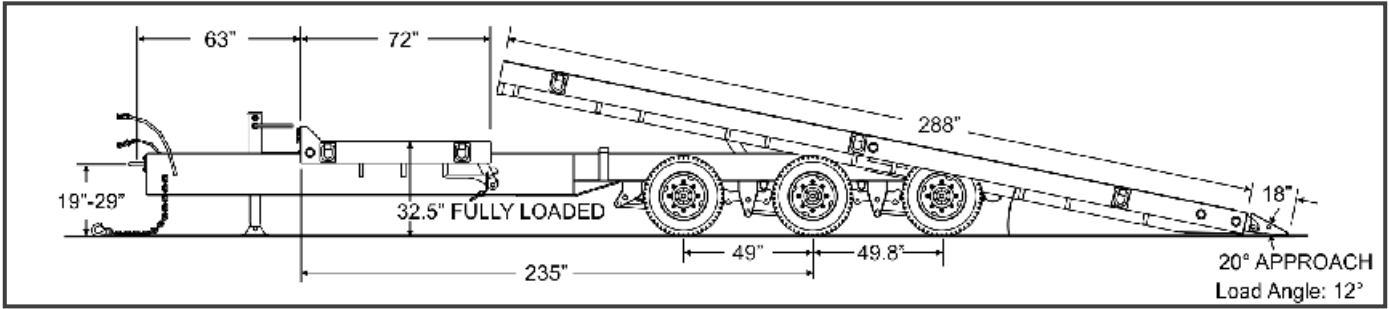

SPECIFICATIONS				
S=Standard O=Optional				
T-50T				
CAPACITY / DIMENSIONS				
Payload Rating (lbs/kg)	50,000 / 22,680			
GVWR (lbs/kg)	62,800 / 28,485			
GAWR (lbs/kg)	54,480 / 24,712			
Approx. Avg. Weight (lbs/kg)	12,800 / 5805			
Overall Length (ft-in/mm)	36-8 / 11,176			
Deck Height (loaded)(in/mm)	32.5 / 826			
Overall Width (ft-in/mm)	8-6 / 2591			
TONGUE				
Tongue Length 5'-2" (1575mm)	S			
Storage Tray with Lid	S			
Pintle Ring (in)	3			
High-Tensile Safety Chain	5/8" Grade 80			
Bolt-on Two-Speed Parking Jack	25K			
FRAME / RAMPS				
Main Beam	W16x26, Gr.50			
One-Piece Cold-Formed Frame Rails	S			
Side Rails (in x in x in)	8x2x1/4 Tubing			
Crossmembers	3" Jr I-beam			
Headboard Height (in/mm)	5.5 / 140			
Deck Length (ft/mm)	24+6 / 7315+1829			
Deck Material	2" nom. White Oak			
Deck Cushion Cylinder	S			
Deck Latch	Dual-Point			
Approach Ramp (in x in/mm)	18 / 457			
Load Angle (degrees)	10			
D-Ring Tie Downs (Total/Side)	10 / 5			
SUSPENSION / TIRES				
Adjustable Hutch 9700 Spring Suspension	S			
No. of Axles	3			
Axle Capacity (each) (lbs/kg)	22,500 / 10,206			
Axle Spread (in/mm)	49 / 1245			
Hubs	Oil Bath			
Brake Size (in/mm)	12.25x7.5 / 311x191			
Air Brakes (Full ABS Modulated, Park Brake All Axles)	S			
Hub Piloted Budd Wheels (in/mm)	17.5x6.75 / 445x171			
Wheel Bolt Pattern	8-bolt			
Tires / Load Range Rating	215/75R17.5 / H			

STANDARD EQUIPMENT

- Adjustable hitch height
- 7-pole round electrical plug
- Weather resistant sealed modular wiring
- Grommet mounted LED lights
- Registration holder
- Rust inhibiting primer
- Durable, rust inhibiting top coat
- Die-cut UV resistant vinyl decals
- D.O.T. approved conspicuity tape
- Mud flaps
- Adjustable ramp width spacing
- Trailer color: Equipment black

OPTIONAL EQUIPMENT

- Rigid gooseneck
- Dual parking jacks
- Additional stationary deck length
- Additional tie-downs
- Tire upgrade (235/75R17.5)
- Spare tire and wheel mount
- Spare tire and wheel
- Color options: Construction Yellow, Equipment Red, Blue, Charcoal
- Galvanizing



Other options may be available. Ask your dealer or visit our website.

*Payload capacity is calculated by taking the GVWR and subtracting the trailer weight. Listed GVWR, weights, and dimensions are for reference only. Manufacturer reserves the right to change models and specifications as they see fit. See our web site or your local authorized dealer for more information.