

TC-9 / TC-10 / TC-12 / TC-14



This small deck over equipment trailer is just the right size for hauling lighter, bulky equipment. The TC-series by Towmaster® features a 5-ft. wood-filled beavertail and 8 ft. wide deck. Dexter® Torflex® axles give this model a predictable, smooth ride. Our patented Auto-Latch® ramp hold-ups are standard and stake pockets provide a secure place for tying equipment. This model is designed for wider small equipment that doesn't require the heavier weight rating of our large deck-over trailers.



Wood topped beavertail and exclusive Auto-Latch® ramp hold-ups.



Stake pockets are standard. Grommet mounted LED lights are standard.



Rubber torsion axles provide smooth suspension and ride.

Quick Specs:

- 31"/33" deck height (loaded)
- 8'-0" deck width
- 14', 16', 18', 20' deck lengths
- Electric brakes
- Stake pockets
- Torflex® suspension/axles
- 5' wood beavertail
- Spring-assist ramps
- Auto-Latch® ramps hold-ups



Photos may show optional equipment.

AMERICA'S BEST BUILT TRAILERS FOR PROFESSIONAL HAULERS



800-462-4517
TOWMASTER.COM



MORE MODELS • MORE OPTIONS • MORE CHOICES
DROP-DECK • TILT BED • DECK-OVER • GOOSENECK • LOWBOY • HYDRAULIC TAIL

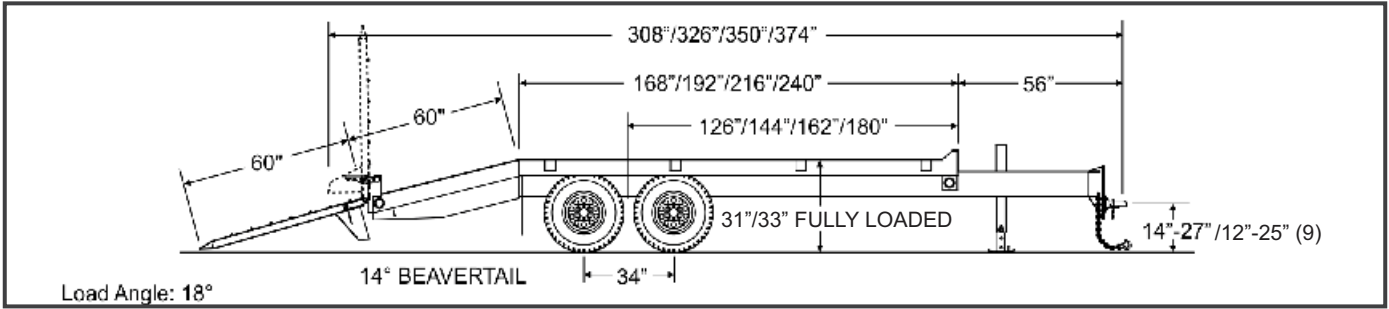

SPECIFICATIONS				
S=Standard O=Optional				
CAPACITY / DIMENSIONS	TC-9	TC-10	TC-12	TC-14
Capacity Rating (lbs/kg)	5,400 / 2449	10,000 / 10,866	12,000 / 5443	14,000 / 6350
GVWR (16 ft. deck, 18 ft. on TC-14) (lbs/kg)	9,990 / 4531	14,600 / 6622	16,600 / 7529	18,800 / 8527
GAWR (lbs/kg)	12,000 / 5443	12,000 / 5443	12,000 / 5443	14,000 / 6350
Approx. Weight (16 ft. deck, 18 ft. on TC-14) (lbs/kg)	4,600 / 2087	4,600 / 2087	4,600 / 2087	4,800 / 2177
Overall Length (14'-0"/4267mm)(ft-in/mm)	25-2 / 7671	25-2 / 7671	25-2 / 7671	N/A
Overall Length (16'-0"/4877mm)(ft-in/mm)	27-2 / 8280	27-2 / 8280	27-2 / 8280	N/A
Overall Length (18'-0"/5486mm)(ft-in/mm)	29-2 / 8890	29-2 / 8890	29-2 / 8890	29-2 / 8890
Overall Length (20'-0"/6096mm)(ft-in/mm)	31-2 / 9500	31-2 / 9500	31-2 / 9500	31-2 / 9500
Deck Height (loaded)(in/mm)	31 / 787	33 / 838	33 / 838	33 / 838
Overall Width (ft-in/mm)	8-0 / 2438	8-0 / 2438	8-0 / 2438	8-0 / 2438
TONGUE				
Tongue Length (ft-in/mm)	4-8 / 1422	4-8 / 1422	4-8 / 1422	4-8 / 1422
Storage Tray	S	S	S	S
Storage Tray Lid	O	O	O	O
Pintle Ring (in)	3"	3"	3"	3"
High-Tensile Safety Chain (size – in)	3/8 Grade 43	3/8 Grade 43	3/8 Grade 43	3/8 Grade 43
Bolt-on Drop-Leg Parking Jack	12K	12K	12K	12K
FRAME / RAMPS				
Main Beam	W10 x 12, Gr. 50	W10 x 12, Gr. 50	W10 x 12, Gr. 50	W10 x 12, Gr. 50
One-Piece Cold-Formed Frame Rails	S	S	S	S
Crossmembers	3" Jr I-beam	3" Jr I-beam	3" Jr I-beam	3" Jr I-beam
Headboard (in/mm)	3.5 / 89	3.5 / 89	3.5 / 89	3.5 / 89
Channel Side Rails (in/mm)	6 / 152	6 / 152	6 / 152	6 / 152
Deck Material	2" nom. White Oak	2" nom. White Oak	2" nom. White Oak	2" nom. White Oak
Tie Downs	Stake Pockets	Stake Pockets	Stake Pockets	Stake Pockets
Tie Downs (Total/Side)	8 / 4	8 / 4	8 / 4	8 / 4
Beavertail (ft-in / mm) (angle-degrees)	5-0 / 1524 (14)	5-0 / 1524 (14)	5-0 / 1524 (14)	5-0 / 1524 (14)
Beavertail Type	Wood Topped	Wood Topped	Wood Topped	Wood Topped
Ladder Style Ramps (ft-in x in/mm)	5-0 x 21 / 1524 x 533	5-0 x 21 / 1524 x 533	5-0 x 21 / 1524 x 533	5-0 x 21 / 1524 x 533
Off-the-Ground Spring Assist	O	O	O	S
Auto-Latch Ramp Hold-Up	S	S	S	S
SUSPENSION / TIRES				
Dexter Torflex Rubber Torsion Suspension	S	S	S	S
No. of Axles	2	2	2	2
Axle Capacity (each) (lbs/kg)	6,000 / 2722	6,000 / 2722	6,000 / 2722	7,000 / 3175
Axle Spread (in/mm)	34 / 864	34 / 864	34 / 864	34 / 864
Hubs	Standard Lube	Standard Lube	Standard Lube	Standard Lube
Electric Brakes	S	S	S	S
Brake Size (in/mm)	12x2 / 305x51	12x2 / 305x51	12x2 / 305x51	12x2 / 305x51
Wheels (in/mm)	15x6 / 381x152	16x6 / 406x152	16x6 / 406x152	16x6 / 406x152
Wheel Bolt Pattern	6-bolt	6-bolt	6-bolt	8-bolt
Tires / Load Range Rating	ST225/75R15 / D	235/85R16 / E	235/85R16 / E	235/85R16 / E

STANDARD EQUIPMENT

- Adjustable hitch height
- RV electrical plug
- Weather resistant sealed modular wiring
- Grommet mounted LED lights
- Registration holder
- Rust inhibiting primer
- Durable, rust inhibiting top coat

- Die-cut UV resistant vinyl decals
- D.O.T. approved conspicuity tape
- Mud flaps
- Adjustable ramp width spacing
- Trailer color: Equipment black
- Ramp color: Equipment Red

OPTIONAL EQUIPMENT

- 2-5/16 ball coupler
- Gooseneck
- 6-pole round electrical plug
- Storage tray lid
- 8K electric winch
- Additional tie-downs
- D-ring tie-downs
- E-Z Lube hubs
- Spare tire and wheel mount
- Spare tire and wheel
- Ramp lift springs (9,10,12)
- Several ramp options
- Color options: Construction Yellow, Equipment Red, Blue, Charcoal
- Galvanizing



Other options may be available. Ask your dealer or visit our website.

*Payload capacity is calculated by taking the GVWR and subtracting the trailer weight. Listed GVWR, weights, and dimensions are for reference only. Manufacturer reserves the right to change models and specifications as they see fit. See our web site or your local authorized dealer for more information.