

**T-14DT / T-16DT
T-18DT / T-20DT**



Towmaster's drop-deck tilt trailers are the most popular tilt-bed trailers on the market. There are no ramps to hassle with; simply tilt the deck and drive on or off. This trailer is built on our cold-formed I-Beam tongue and main frame for tough durability. The tilt deck trailer features a single lever twin-latch system, knife-edge approach, rubber-ride axles and adjustable hitch. A deck cushion cylinder eases the deck back into transport position and prevents it from slamming onto the frame while loading.



Cushion cylinder controls the deck when loading or unloading equipment.



Single deck lever with dual latch securement is easy to operate.



Quick Specs:

- 2" nom. white oak deck
- 19" deck height (unload)
- 82" load with
- 16' or 18' deck
- EZ lube axles
- Forward adjusting electric brakes
- One-piece formed fender
- Low approach angle

Photos may show optional equipment.

PROFESSIONAL HAULERS DEMAND TOWMASTER



800-462-4517
TOWMASTER.COM



MORE MODELS • MORE OPTIONS • MORE CHOICES
DROP-DECK • TILT BED • DECK-OVER • GOOSENECK • LOWBOY • HYDRAULIC TAIL

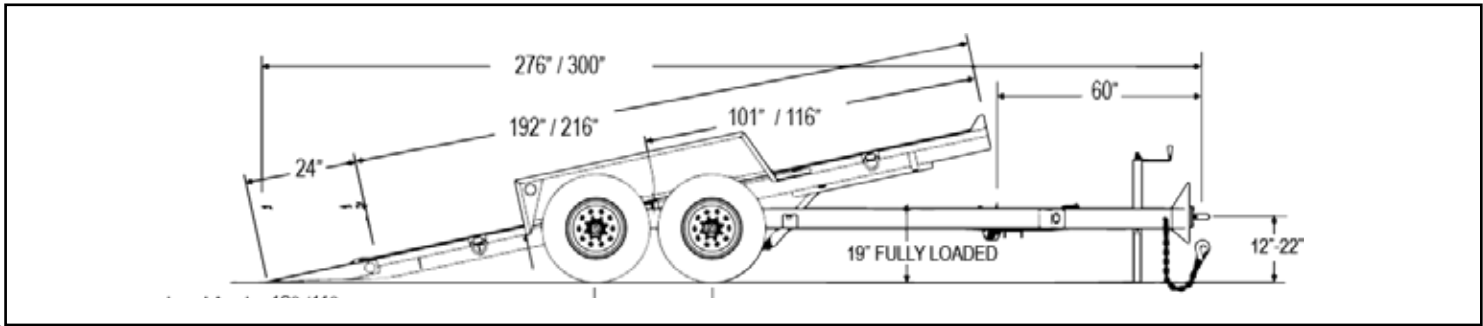

All dimensions are nominal. Illustration may be shown with optional equipment.

Standard Features

Hitch/Tongue

- Adjustable height, bolt-on coupler
- 3" pintle
- RV plug
- One-piece cold-formed frame rails
- Integrated storage tray
- 12K bolt-on side-wind parking jack
- Battery break-away kit with tow charger & test light
- Safety chains with hooks

Frame/Deck

- 80" load width (T-18DT, T-20DT)
- 82" load width (T-14DT, T-16DT)
- 19" deck height (fully loaded)
- Deck cushion cylinder
- Dual-point, single lever deck lock
- 6" I-beam main frame (T-14DT, T-16DT)
- 10" I-beam main frame (T-18DT, T-20DT)
- 3" channel crossmembers
- 2" nom. white oak deck
- D-ring tie-downs (4 per side)
- 12 gauge one-piece formed fender

Axles/Suspension

- Rubber-ride suspension axles
- 7,200 lb. axles (4 wheels) (T-14-DT)
- 8,000 lb. axles (4 wheels) (T-16DT)
- 10,000 lb. axles (4 wheels) (T-18DT, T-20DT)
- Tires - 215/75R17.5 load range H, 16-ply
- Tires - 215/75R15.5 (H) (T-20DT)
- 17.5" wheels, 8-bolt
- Electric brakes
- EZ Lube hubs
- Oil bath hubs (T-18DT/20DT)

Lights/Wiring

- Rubber grommet mounted LED lights
- Sealed modular wiring

Standard Features

- Limited Lifetime Frame Warranty
- One-Year full Warranty
- 10 Year Suspension Warranty
- Weatherproof registration holder
- Two-component polyurethane primer and paint
- Trailer color: Equipment Black

Trailer	GAWR (lbs)	GVWR (lbs)	Weight (lbs)	Capacity (lbs)	Deck Width (in)	Deck Length (ft)
T-14DT	14,400	18,300/18,600	4,300/4,600	14,000	82"	16'/18'
T-16DT	16,000	20,400/20,700	4,400/4,700	16,000	82"	16'/18'
T-18DT	20,000	22,400/22,700	4,400/4,700	18,000	80"	16'/18'
T-20DT	20,000	24,400/24,700	4,400/4,700	20,000	80"	16'/18'

Optional Equipment

- | | | | |
|--------------------------------|------------------------|--|---|
| • 5ft. or 6ft. Stationary deck | • Pallet fork holders | • Spare tire and wheel | • Color options: Construction Yellow, Equipment Red, Blue, Charcoal |
| • Gooseneck hitch | • 9K electric winch | • "SL" ramp option for hauling scissor lifts | • Galvanizing |
| • 6-pole round electrical plug | • Additional tie-downs | | |
| • Storage tray lid | • Spare tire mount | | |

Other options may be available. Ask your dealer or visit our website.

Listed GVWR, weights and dimensions are for reference only. Manufacturer reserves the right to change models and specifications as they see fit. See our web site or your local authorized dealer for more information.